

**TECHNICAL INFORMATION FOR TGS2612**



an ISO9001/14001 company

**Technical Information for Methane & Propane Gas Sensors**

The Figaro 2600 series is a new type thick film metal oxide semiconductor, screen printed gas sensor which offers miniaturization and lower power consumption. The TGS2612 displays high selectivity and sensitivity to both methane and LP gas and its components (e.g. propane and butane).



*Page*

**Specifications**

Features.....2  
 Applications.....2  
 Structure.....2  
 Basic Measuring Circuit.....2  
 Circuit & Operating Conditions.....3  
 Specifications.....3  
 Dimensions.....3

**Basic Sensitivity Characteristics**

Sensitivity to Various Gases.....4  
 Temperature and Humidity Dependency.....5  
 Heater & Circuit Voltage Dependency.....6  
 Gas Response.....6  
 Initial Action.....7  
 Long Term Characteristics.....7

**Reliability**

Gas Exposure Test.....8  
 Corrosion Test.....8  
 Ignition Test.....9  
 Heater Resistance Durability.....9

**Cautions.....10**

*See also Technical Brochure 'Technical Information on Usage of TGS Sensors for Toxic and Explosive Gas Leak Detectors'.*

**IMPORTANT NOTE:** OPERATING CONDITIONS IN WHICH FIGARO SENSORS ARE USED WILL VARY WITH EACH CUSTOMER'S SPECIFIC APPLICATIONS. FIGARO STRONGLY RECOMMENDS CONSULTING OUR TECHNICAL STAFF BEFORE DEPLOYING FIGARO SENSORS IN YOUR APPLICATION AND, IN PARTICULAR, WHEN CUSTOMER'S TARGET GASES ARE NOT LISTED HEREIN. FIGARO CANNOT ASSUME ANY RESPONSIBILITY FOR ANY USE OF ITS SENSORS IN A PRODUCT OR APPLICATION FOR WHICH A SENSOR HAS NOT BEEN SPECIFICALLY TESTED BY FIGARO.



TGS2612 is a UL recognized component in accordance with the requirements of UL2075. Please note that component recognition testing has confirmed long term stability in 60ppm of propane; other characteristics shown in this brochure have not been confirmed by UL as part of component recognition.

1. Specifications

1-1 Features

- \* High selectivity to both methane and LP gas
- \* Low power consumption
- \* Small size
- \* Long life and low cost
- \* Uses simple electrical circuit

1-2 Applications

- \* Residential methane and LP gas leak detectors

1-3 Structure

Figure 1 shows the structure of TGS2612. Using thick film techniques, the sensing material (SnO<sub>2</sub>) is printed on electrodes (noble metal) which have been printed onto an alumina substrate. One electrode is connected to pin No.2 and the other is connected to pin No.3. The sensor element is heated by RuO<sub>2</sub> material printed onto the reverse side of the substrate and connected to pins No.1 and No.4.

Lead wires are Pt-W alloy and are connected to sensor pins which are made of Ni-plated Ni-Fe 50%.

The sensor base is made of Ni-plated steel. The cap is stainless steel. The upper opening is covered with a double layer of 100 mesh stainless steel gauze (SUS316). TGS2612 utilizes an adsorbent inside the cap for reducing the influence of interference gases.

1-4 Basic measuring circuit

Figure 2 shows the basic measuring circuit. Circuit voltage (V<sub>C</sub>) is applied across the sensor element which has a resistance (R<sub>S</sub>) between the sensor's two electrodes and the load resistor (R<sub>L</sub>) connected in series. When DC is used for V<sub>C</sub>, the polarity shown in Figure 2 **must** be maintained. The V<sub>C</sub> may be applied intermittently. The sensor signal (V<sub>RL</sub>) is measured indirectly as a change in voltage across the R<sub>L</sub>. The R<sub>S</sub> is obtained from the formula shown at the right.

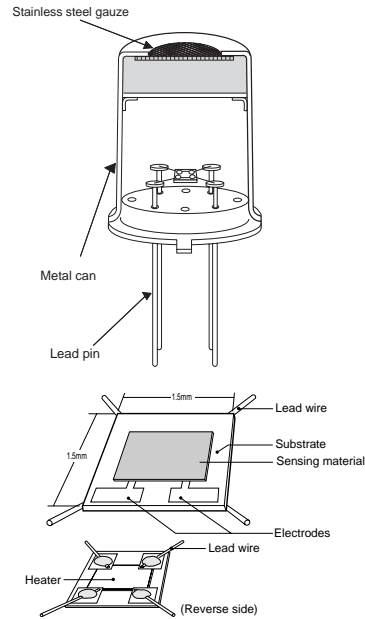

Fig. 1 - Sensor structure

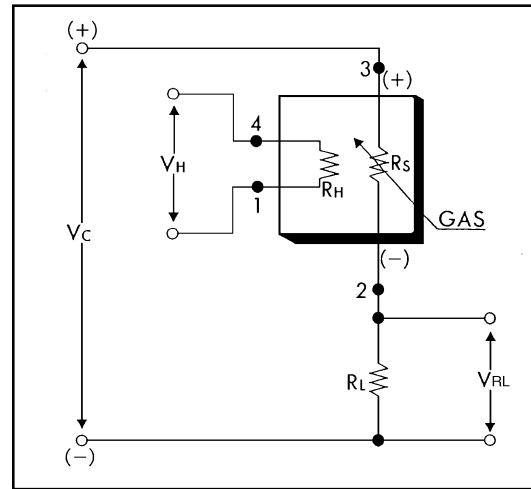

Fig. 2 - Basic measuring circuit

**NOTE:** In the case of V<sub>H</sub>, there is no polarity, so pins 1 and 4 can be considered interchangeable. However, in the case of V<sub>C</sub>, when used with DC power, pins 2 and 3 must be used as shown in the Figure above.

$$R_S = \frac{V_C - V_{RL}}{V_{RL}} \times R_L$$

Formula to determine R<sub>S</sub>

1-5 Circuit & operating conditions

The ratings shown below should be maintained at all times to insure stable sensor performance:

Item	Specification
Circuit voltage (Vc)	5.0V ± 0.2V DC/AC
Heater voltage (VH)	5.0V ± 0.2V DC/AC
Inrush heater current (VH=5.0V)	100mA max.
Heater resistance (room temp.)	approx. 59Ω
Load resistance (RL)	variable (0.45kΩ min.)
Sensor power dissipation (Ps)	≤ 15mW
Operating & storage temperature	-40°C ~ +70°C
Optimal detection concentration	1~25%LEL of each gas

1-6 Specifications NOTE 1

Item	Specification
Sensor resistance (5000ppm methane)	0.68kΩ ~ 6.8kΩ
Sensor resistance gradient (β)	0.50 ~ 0.65
$\beta = R_s(9000\text{ppm methane})/R_s(3000\text{ppm methane})$	
Cross sensitivity (corresponding with 10%LEL methane)	≤25% LEL propane ≤25%LEL iso-butane
Heater current	56 ± 5mA
Heater power consumption	approx. 280mW

**NOTE 1:** Sensitivity characteristics are obtained under the following standard test conditions:

(Standard test conditions)

Test gases: Methane, propane & isobutane in air

Temperature and humidity: 20 ± 2°C, 65 ± 5% RH

Circuit conditions: Vc = 5.0±0.01V DC

VH = 5.0±0.05V DC

RL = 10.0kΩ ± 1%

Preheating period: 7 days or more under standard circuit conditions

All sensor characteristics shown in this brochure represent typical characteristics. Actual characteristics vary from sensor to sensor and from production lot to production lot. The only characteristics warranted are those shown in the Specification table above.

1-7 Dimensions

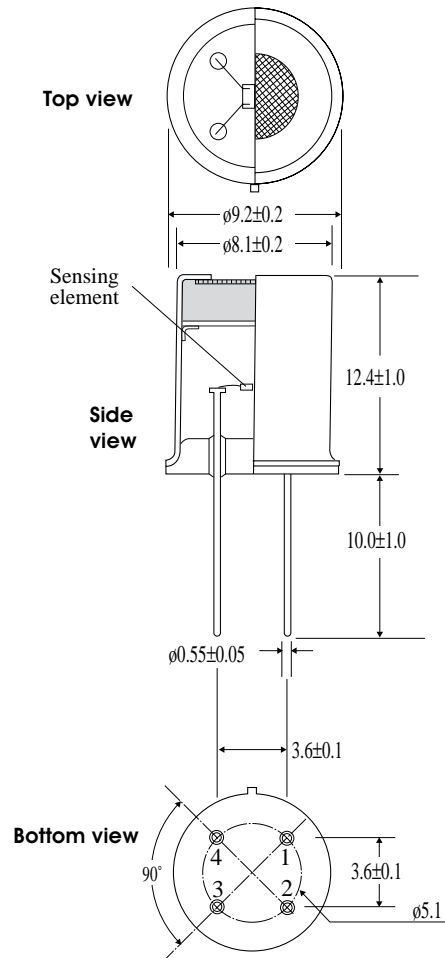

**Pin connection:**

- 1: Heater
- 2: Sensor electrode (-)
- 3: Sensor electrode (+)
- 4: Heater

Fig. 3 - Sensor dimensions

**Mechanical Strength:**

The sensor shall have no abnormal findings in its structure and shall satisfy the above electrical specifications after the following performance tests:

**Withdrawal Force** - withstand force of 5kg in each (pin from base) direction

**Vibration** - frequency-1000c/min., total amplitude-4mm, duration-one hour, direction-vertical

**Shock** - acceleration-100G, repeated 5 times

2. Basic Sensitivity Characteristics

2-1 Sensitivity to various gases

Figure 4 shows the relative sensitivity of TGS2612 to various gases. The Y-axis shows the ratio of the sensor resistance in various gases ( $R_s$ ) to the sensor resistance in 5000ppm of methane ( $R_o$ ).

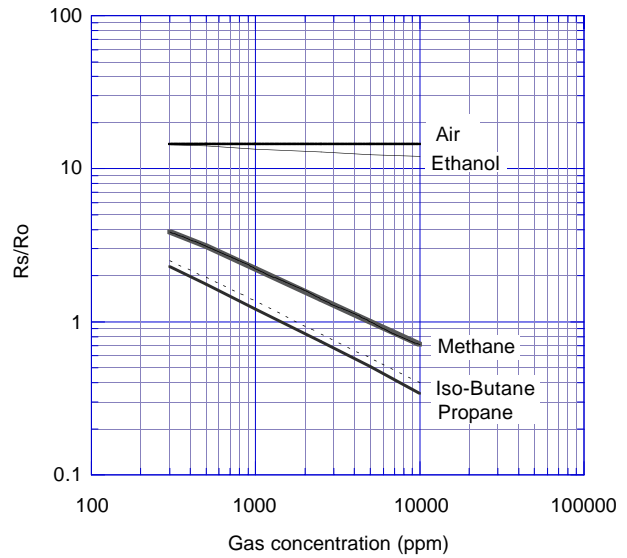

Fig. 4 - Sensitivity to various gases ( $R_s/R_o$ )

Using the basic measuring circuit illustrated in Fig. 2, and with a matched RL value equivalent to the  $R_s$  value in 5000ppm of methane, will provide the sensor output voltage (VRL) change as shown in Figure 5.

**NOTE:**

All sensor characteristics in this technical brochure represent typical sensor characteristics. Since the  $R_s$  or output voltage curve varies from sensor to sensor, calibration is required for each sensor (for additional information on calibration, please refer to the Technical Advisory 'Technical Information on Usage of TGS Sensors for Toxic and Explosive Gas Leak Detectors').

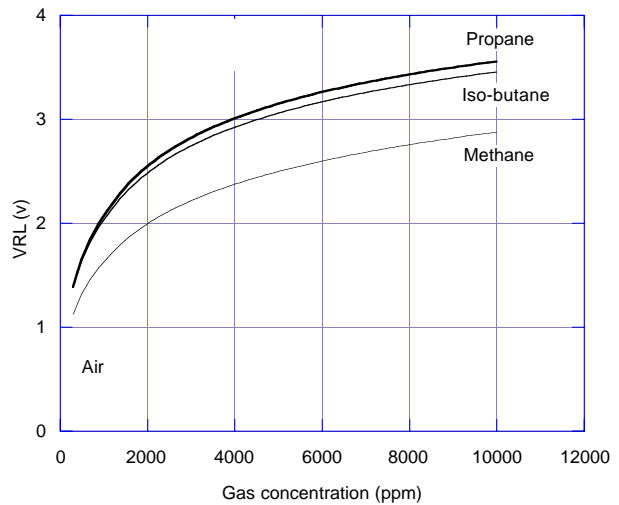

Fig. 5 - Sensitivity to various gases (VRL)

2-2 Temperature and humidity dependency

Figure 6 shows the temperature and humidity dependency of TGS2612. The Y-axis shows the ratio of sensor resistance at 10%LEL of each gas under various atmospheric conditions ( $R_s$ ) to the sensor resistance at 10%LEL of each gas at various temperatures and 65%RH ( $R_o$ ).

R.H. (°C)	65%RH		
	5000ppm methane	2100ppm propane	1800ppm iso-butane
-10	2.13	1.91	1.84
0	1.63	1.57	1.52
10	1.27	1.26	1.24
20	1.00	1.00	1.00
30	0.83	0.81	0.80
40	0.73	0.65	0.62

Table 1 - Temperature and humidity dependency (typical values of  $R_s/R_o$  for Fig. 6)

Table 1 shows a table of values of sensor resistance ratio ( $R_s/R_o$ ) under the same conditions as those used to generate Figure 6.

Figure 7 shows the sensitivity curve for TGS2612 to methane under several ambient conditions. While temperature may have a large influence on absolute  $R_s$  values, this chart illustrates the fact that effect on the slope of sensor resistance ratio ( $R_s/R_o$ ) is not significant. As a result, the effects of temperature on the sensor can easily be compensated.

For economical circuit design, a thermistor can be incorporated to compensate for temperature (for additional information on temperature compensation in circuit designs, please refer to the Technical Advisory 'Technical Information on Usage of TGS Sensors for Toxic and Explosive Gas Leak Detectors').

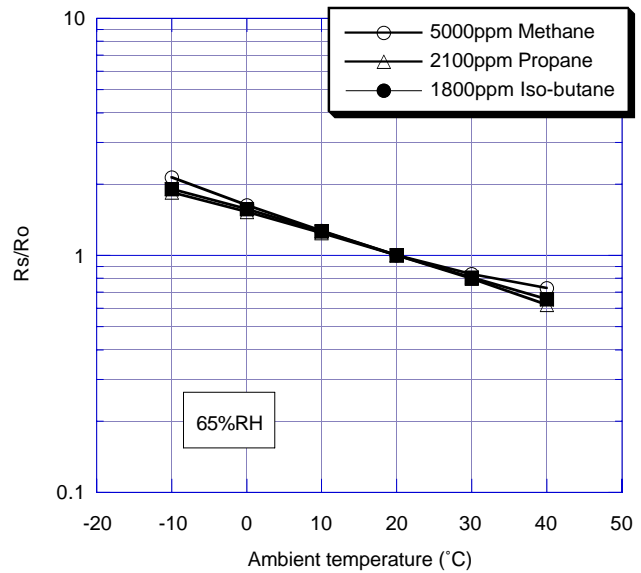

Fig. 6 - Temperature and humidity dependency ( $R_s/R_o$ )

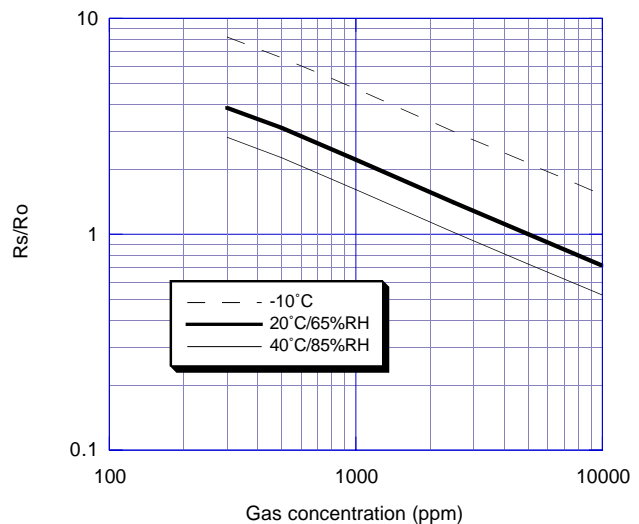

Fig. 7 - Sensor resistance under various ambient conditions

2-3 Heater voltage dependency

Figure 8 shows the change in the sensor resistance ratio according to variations in the heater voltage (VH).

Note that 5.0V as a heater voltage must be maintained because variance in applied heater voltage will cause the sensor's characteristics to be changed from the typical characteristics shown in this brochure.

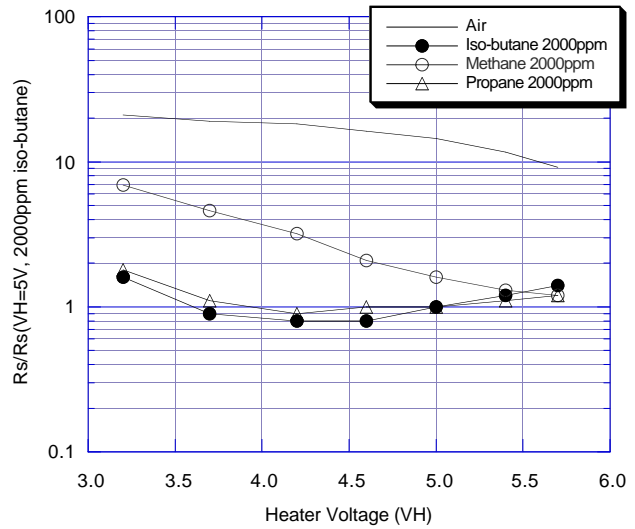

Fig. 8 - Heater voltage dependency (Vc=5.0)

2-4 Gas response

Figures 9a and 9b show the change pattern of sensor resistance (Rs) when the sensor is inserted into and later removed from 5000ppm of methane and 1800ppm of iso-butane respectively.

As these charts display, the sensor's response speed to the presence of gas is extremely quick, and when removed from gas, the sensor will recover back to its original value in a short period of time.

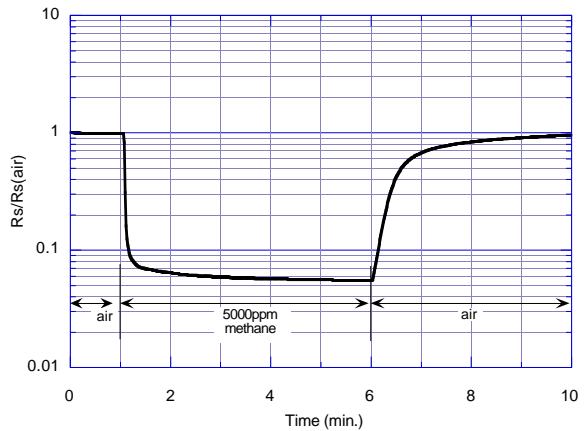

Fig. 9a - Gas response to methane

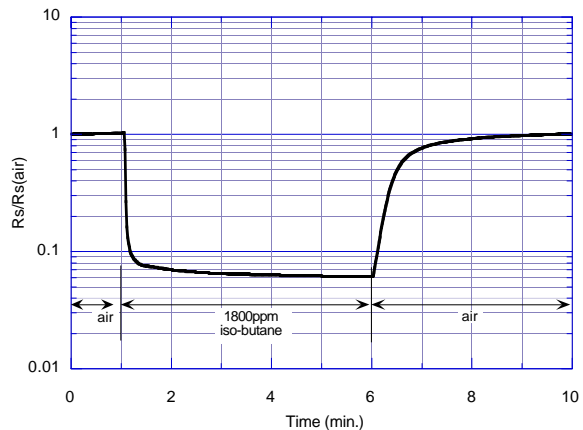

Fig. 9b - Gas response to iso-butane

2-5 Initial action

Figure 10 shows the initial action of the sensor resistance ( $R_s$ ) for a sensor which is stored unenergized in normal air for 30 days and later energized in clean air.

The  $R_s$  drops sharply for the first seconds after energizing, regardless of the presence of gases, and then reaches a stable level according to the ambient atmosphere. Such behavior during the warm-up process is called "Initial Action".

Since this 'initial action' may cause a detector to alarm unnecessarily during the initial moments after powering on, it is recommended that an initial delay circuit be incorporated into the detector's design (refer to Technical Advisory 'Technical Information on Usage of TGS Sensors for Toxic and Explosive Gas Leak Detectors'). This is especially recommended for intermittent-operating devices such as portable gas detectors.

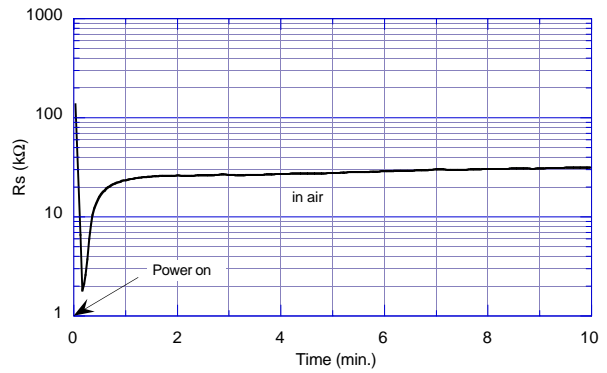

Fig. 10 - Initial action

2-6 Long-term characteristics

Figure 11 shows long-term stability of TGS2612 as measured for more than 500 days. The sensor is first energized in normal air. Measurement for confirming sensor characteristics is conducted under standard test conditions. The initial value of  $R_s$  was measured after two days energizing in normal air at the rated voltage. The Y-axis represents the sensor resistance in air, 1800ppm of iso-butane, 1000ppm of propane, and 5000ppm of methane.

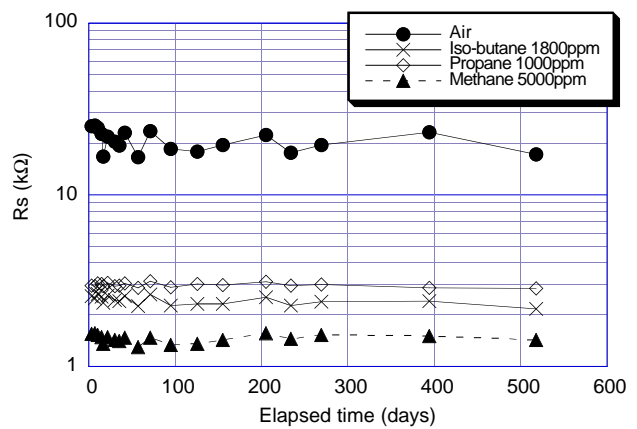

Fig. 11 - Long-term stability (continuous energizing)

The  $R_s$  in methane, iso-butane, and propane is very stable over the test period.

Figure 12 shows the influence of storage in an unenergized condition on the sensor's resistance. The sensors were stored unenergized in air after 20 days energizing, then energized for one hour before a measurement was taken.

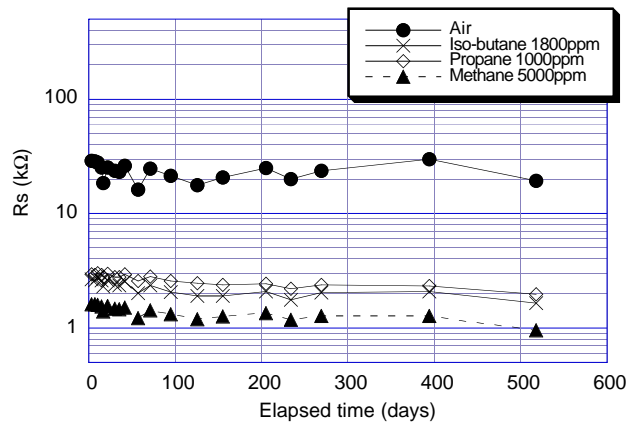

Fig. 12 - Influence of unenergizing

As the charts presented in this section illustrate, the sensor shows stable long term characteristics.

### 3. Reliability

#### 3-1 Gas exposure test

Figure 13 shows the test procedure of short-term high concentration exposure to a 100% concentration of iso-butane gas. During this test, the sensor was kept energized under conditions of 20°C/65%RH. The sensor resistance in 1000ppm of propane, 5000ppm of methane, and 1800ppm of iso-butane was measured before and after the gas exposures. All exposures in gas during this test were followed by exposure in normal air.

As this section illustrates, exposure to 100% iso-butane appears to cause an increase in  $R_s$  in gas. Although the sensor resistance decreases after returning to normal air, the resistance does not fully recover to its original level even one week after the exposure. This kind of permanent change to sensor characteristics would be due to combustion on the surface of the sensing material and/or heater. Because of this, prolonged exposure to 100% iso-butane should be avoided.

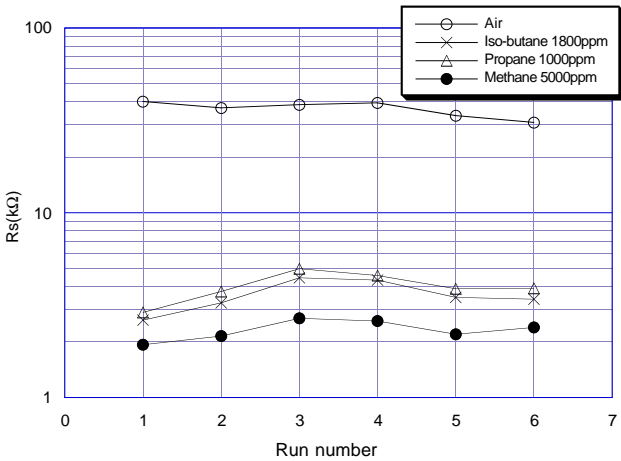

Fig. 13 - Effect of high concentration iso-butane exposure on  $R_s$

#### Run number

- 1 - Initial
- 2 - After exposure to 100% iso-butane for 10 sec.
- 3 - After exposure 3 times to 100% iso-butane for 10 sec.
- 4 - 1 day after exposure
- 5 - 3 days after exposure
- 6 - 1 week after exposure

#### 3-2 HMDS Test

Figure 14 shows the effects of silicone vapor on TGS2612. Prior to exposure to HMDS (hexamethyl disiloxane), the sensor resistance in normal air ( $R_0$ ) was measured. Next, energized sensors were placed into an environment of 20°C/65%RH and then exposed to 10ppm of HMDS for 2 hours. This condition is 36 times longer than that specified in Item 5.3.13 of the European standard (EN50194). After exposure, the sensor was returned to normal air. Sensor resistance ( $R_s$ ) was then measured in air, 1000 and 3000ppm of methane, and 1000 and 3000ppm of iso-butane. These measurements were taken one hour and 10 days after being removed from HMDS.

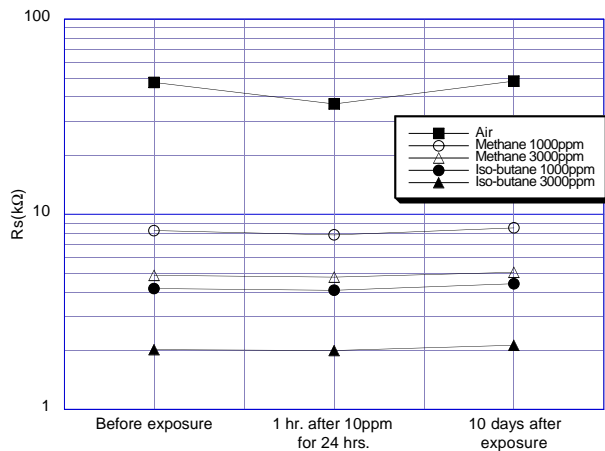

Fig. 14 - Effect of HMDS exposure

As this data would suggest, sensor characteristics remain largely unaffected by exposure to HMDS gas concentrations specified by performance standards.

Higher HMDS gas concentrations may affect sensor characteristics. Silicone vapor (which is of a low



molecular weight) can easily be thermally decomposed to silicone dioxide (SiO<sub>2</sub>) at the sensor's working temperature. Decomposed SiO<sub>2</sub> would cause deactivation of the catalyst in the sensing material and therefore decrease the sensor's resistance in air, altering its sensitivity to gas.

### 3-3 Ignition test

TGS2612 has been successfully tested against the ignition test requirements of the UL1484 standard. The sensor did not initiate ignition of a propane concentration of 5.25% by volume.

### 3-4 Heater resistance durability

Figure 15 illustrates the procedure for testing the effects of excess voltage applied to the heater. Heater resistance was measured while the heater was unpowered and at room temperature.

The results of this test are shown in Figure 16 which shows the change in resistance of the heater when various heater voltages (rather than the standard 5.0v) are applied in the absence of gases.

As this section demonstrates, the heater shows good durability against increased heater voltage. However, since excessive heater voltage will cause the sensor's heater resistance to drift upwards, excessive heater voltage should still be avoided.

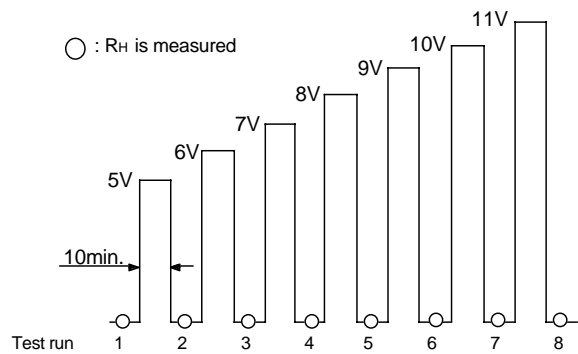

Fig. 15 - Test procedure for gas exposure

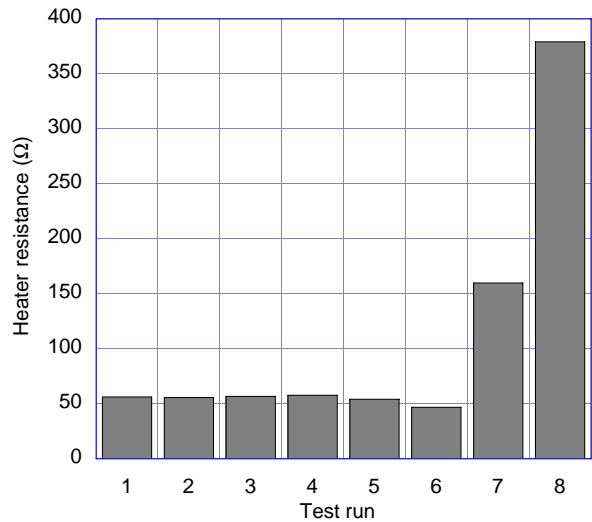

Fig. 17 - Effect of gas exposure on heater current

#### 4 Cautions on Usage of Figaro Gas Sensors

##### 4-1 Situations which must be avoided

###### 1) Exposure to silicone vapors

If silicone vapors adsorb onto the sensor's surface, the sensing material will be coated, irreversibly inhibiting sensitivity. Avoid exposure where silicone adhesives, hair grooming materials, or silicone rubber/putty may be present.

###### 2) Highly corrosive environment

High density exposure to corrosive materials such as H<sub>2</sub>S, SO<sub>x</sub>, Cl<sub>2</sub>, HCl, etc. for extended periods may cause corrosion or breakage of the lead wires or heater material.

###### 3) Contamination by alkaline metals

Sensor drift may occur when the sensor is contaminated by alkaline metals, especially salt water spray.

###### 4) Contact with water

Sensor drift may occur due to soaking or splashing the sensor with water.

###### 5) Freezing

If water freezes on the sensing surface, the sensing material would crack, altering characteristics.

###### 6) Application of excessive voltage

If higher than specified voltage is applied to the sensor or the heater, lead wires and/or the heater may be damaged or sensor characteristics may drift, even if no physical damage or breakage occurs.

###### 7) Operation in zero/low oxygen environment

TGS sensors require the presence of around 21% (ambient) oxygen in their operating environment in order to function properly and to exhibit characteristics described in Figaro's product literature. TGS sensors cannot properly operate in a zero or low oxygen content atmosphere.

##### 4-2 Situations to be avoided whenever possible

###### 1) Water condensation

Light condensation under conditions of indoor usage should not pose a problem for sensor performance. However, if water condenses on the sensor's surface

and remains for an extended period, sensor characteristics may drift.

###### 2) Usage in high density of gas

Sensor performance may be affected if exposed to a high density of gas for a long period of time, regardless of the powering condition.

###### 3) Storage for extended periods

When stored without powering for a long period, the sensor may show a reversible drift in resistance according to the environment in which it was stored. The sensor should be stored in a sealed bag containing clean air; do not use silica gel. *Note that as unpowered storage becomes longer, a longer preheating period is required to stabilize the sensor before usage.*

###### 4) Long term exposure in adverse environment

Regardless of powering condition, if the sensor is exposed in extreme conditions such as very high humidity, extreme temperatures, or high contamination levels for a long period of time, sensor performance will be adversely affected.

###### 5) Vibration

Excessive vibration may cause the sensor or lead wires to resonate and break. Usage of compressed air drivers/ultrasonic welders on assembly lines may generate such vibration, so please check this matter.

###### 6) Shock

Breakage of lead wires may occur if the sensor is subjected to a strong shock.

###### 7) Soldering

Ideally, sensors should be soldered manually. However, wave soldering can be done under the following conditions:

a) Suggested flux: rosin flux with minimal chlorine

b) Speed: 1-2 meters/min.

c) Preheating temperature: 100±20°C

d) Solder temperature: 250±10°C

e) Up to two passes through wave soldering machine allowed

Results of wave soldering cannot be guaranteed if conducted outside the above guidelines since some flux vapors may cause drift in sensor performance similar to the effects of silicone vapors.

**NOTE:** To achieve the optimal level of accuracy in gas detectors, each TGS2612 sensor should be individually calibrated by matching it with a load resistor (RL) in an environment containing the target gas concentration for alarming (refer to Fig. 2).

For the convenience of users, TGS2612 is classified into 24 groups according to the each sensor's Rs in isobutane. ID numbers marked on the sensor's body indicate the sensor's grouping. Individual sensor calibration can be eliminated by matching the sensor with the recommended RL for each sensor ID. However, because group calibration is used instead of individual calibration, an average of 10% less accuracy would result for detectors using group calibration.

---

Figaro USA Inc. and the manufacturer, Figaro Engineering Inc. (together referred to as Figaro) reserve the right to make changes without notice to any products herein to improve reliability, functioning or design. Information contained in this document is believed to be reliable. However, Figaro does not assume any liability arising out of the application or use of any product or circuit described herein; neither does it convey any license under its patent rights, nor the rights of others.

Figaro's products are not authorized for use as critical components in life support applications wherein a failure or malfunction of the products may result in injury or threat to life.