

Technical Information for Nitric Oxide Sensors

The FECS41-250 is an electrochemical-type gas sensor which has high sensitivity to nitric oxide, high selectivity, and a stable baseline.



	<i>Page</i>
<i>Basic Information and Specifications</i>	
Features.....	2
Applications.....	2
Basic Measuring Circuit.....	2
Operating Conditions and Specifications.....	2
Structure and Dimensions.....	2
<i>Operation Principle.....</i>	<i>3</i>
<i>Basic Sensitivity Characteristics</i>	
Sensitivity Characteristics.....	4
Gas Response.....	4
Repeatability.....	4
Cross Sensitivity.....	5
Temperature Dependency.....	5
<i>Cautions.....</i>	<i>6</i>
<i>Warranty.....</i>	<i>7</i>
<i>Frequently Asked Questions.....</i>	<i>7</i>

1. Specifications

1-1 Features

- * High sensitivity/selectivity to NO
- * Quick response to NO
- * Linear output
- * Long life
- * Stable baseline
- * Unique leak-proof structure

1-2 Applications

- * Portable and fixed installation NO monitors
- * NO detectors
- * Ventilation control for indoor parking garages

1-3 Basic Measuring Circuit

Figure 1 shows the basic measuring circuit for use with FECS41-250.

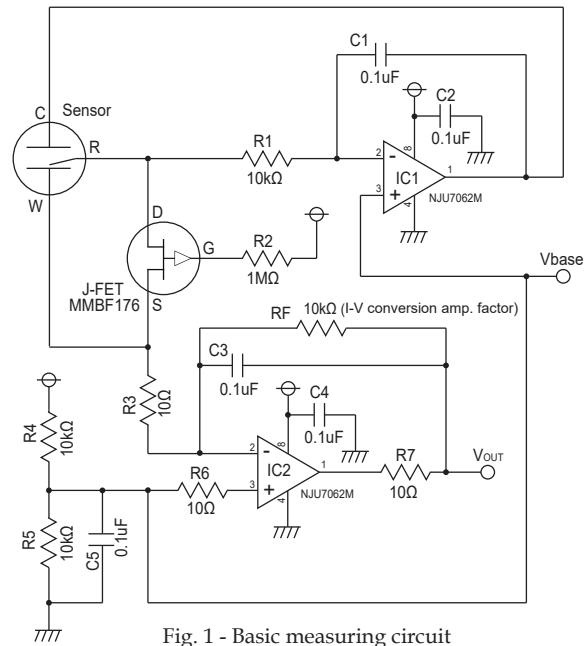

Fig. 1 - Basic measuring circuit

Notes:

1) Sensor output current $I_{OUT}(A)$ is calculated from output voltage $V_{OUT}(V)$:

$$I_{OUT}(A) = (V_{OUT}[Gas] - V_{OUT}[Air]) / RF$$

where: $V_{OUT}[Gas]$: sensor output voltage in target gas
 $V_{OUT}[Air]$: sensor output voltage in zero air
 RF: I-V conversion amp. factor

If sensor output is too small to measure for the application, change an I-V conversion amp. factor (RF) which is larger than 10 kΩ, such as 33~330kΩ.

2) Recommended load resistor R3 is 10Ω. If the noise is large, it may be improved by increasing R3 a little. However, gas response becomes slower.

1-4 Operating Conditions & Specifications (Table 1)

(*) Standard test conditions: 20°C/50%RH and 1013 hPa.

(**)The end of life for FECS41-250 sensors is specified as the point at which output signal is reduced to 60% from the initial output signal of the sensor.

(***) Please refer to 4-1 2) Storage conditions

1-5 Structure & Dimensions

The sensor consists of three electrode pins and a resin housing, and a pre-filter (white) is attached to the top of the housing. In addition, the electrolyte,

Model Number	FECS41-250
Detection Gas	Nitric Oxide
Detection Range	0 ~ 250 ppm
Maximum Overload	1000 ppm
Output Signal	400 ± 80 nA/ppm (*)
Repeatability	± 2% (*)
Resolution	0.5 ppm (*)
Baseline Range (Clean air)	0 ~ 3 ppm (*)
Response Time (t90)	< 40 sec(*)
Baseline Shift (-20 ~ 40°C)	< 4 ppm (*)
Long Term Output Drift	< 2% /month (*)
Expected Life Time	> 2 years (*)(**)
Operating Temperature	-20 ~ 50°C
Operating Humidity	15 ~ 90% RH
Operating Pressure Range	1013 hPa ±10%
Recommended Load Resistor	10Ω
Bias Voltage	+ 300 mV
Position Sensitivity	None
Recommended Storage Temp. (***)	0 ~ 20°C
Cap Color	Orange
Weight	4.5g (approx.)

Table 1 - Specifications of FECS41-250

electrodes and filters necessary for electrochemical reaction are built inside the housing. Around the outer circumference of the housing, a dedicated label that contains the target gas, model number, and serial number is wrapped. Figure 2 shows the dimensions of the sensor.

2. Operation Principle

FECS-series electrochemical-type gas sensors consist of a working electrode where an oxidation (reduction) reaction occurs, a counter electrode where a reduction (oxidation) reaction occurs at the same time, and a reference electrode that monitors the potential change that occurs at the sensing electrode at this time. In the operating state, based on the potential detected by the reference electrode, the externally connected potentiostat circuit keeps the working electrode at a preset constant potential. The effect of the reference electrode is to detect the potential of the working electrode and keep the potential of the working electrode constant regardless of this voltage drop, allowing a current that is always proportional to the gas concentration to flow between the working electrode and the counter electrode. Electrochemical gas sensors having the function of controlling the potential by such a reference electrode are called "Three-electrode cell type sensor" or "Controlled potential electrolysis type sensor". These type sensors are widely used as industrial electrochemical gas sensors because of their excellent linearity to gas and output stability. (refer to Figure 3)

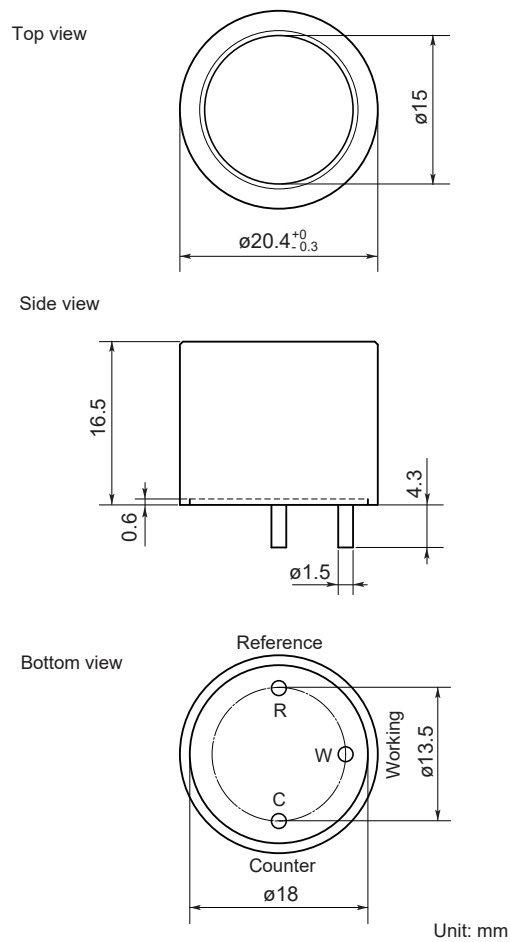

All tolerance $\pm 0.1\text{mm}$ unless otherwise stated.

Fig. 2 - Sensor dimensions

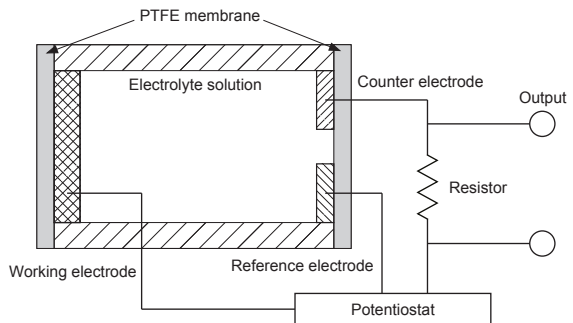

Fig. 3 - Schematic diagram of operating principle

3. Basic Sensitivity Characteristics

3-1 Sensitivity Characteristics

Figure 4 shows the typical sensitivity characteristics (linearity) for NO of FECS41-250 measured using the recommended basic measuring circuit. FECS41-250 has excellent linearity to NO.

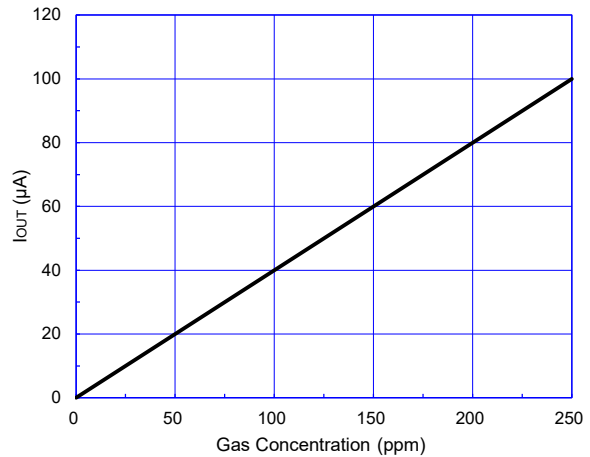

Fig. 4 - Typical sensitivity characteristics of FECS41-250

3-2 Gas Response

Figure 5 demonstrates the response pattern of the sensor output of FECS41-250 measured by using recommended basic measuring circuit when the sensor is inserted into and later removed from 100ppm of NO at 20°C/50%RH, and 1013hPa. Typical response time to 90% of saturated response is 40 seconds for FECS41-250.

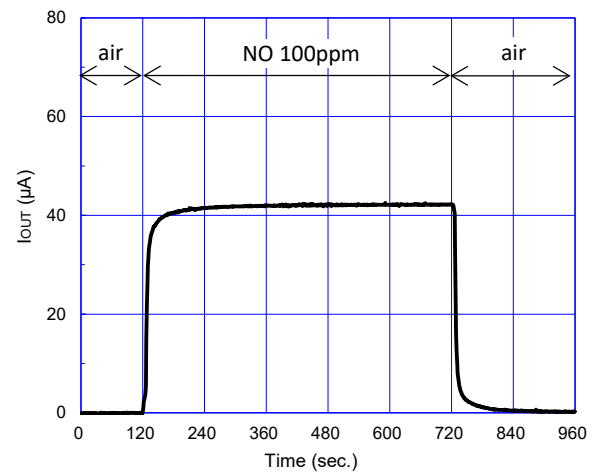

Fig. 5 - Response to nitric oxide of FECS41-250

3-3 Repeatability

Figure 6 demonstrates the sensor's repeatability by showing multiple exposures of FECS41-250 to 100ppm of NO measured using the recommended basic measuring circuit. The sensor is inserted into 100ppm of NO for 10 minutes and later removed from gas at 10 minutes.

This graph shows the response pattern repeated 5 times. Good repeatability can be seen in the test result.

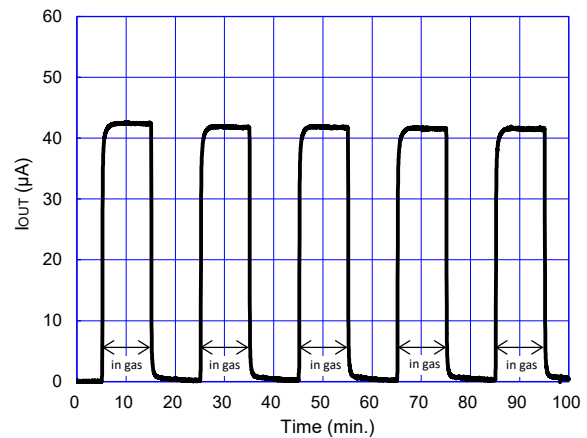

Fig. 6 - Repeatability of FECS41-250

3-4 Cross Sensitivity

Table 2 shows the typical response of FECS41-250 to interference gases under standard test conditions. As shown in this table, the sensor has almost no sensitivity to gases other than NO and has excellent selectivity to NO.

Gas	Concentration (ppm)	Typical Nitric Oxide Concentration(ppm) Equivalent
Nitric Oxide	100	100
Carbon Monoxide	300	0
Carbon Dioxide	5,000	0
Hydrogen	1,000	0
Sulphur Dioxide	20	0
Hydrogen Sulfide	15	< 4
Nitrogen Dioxide	5	< 1
Ammonia	20	0
Chlorine	10	0

Table 2 - Cross sensitivity of FECS41-250 (20°C)

3-5 Temperature Dependency

Figure 7 shows the sensitivity change with temperature measured using the recommended basic measuring circuit. The Y-axis shows the ration of output current in 100ppm of NO at various temperatures (I) to the output current in 100ppm of NO at 20°C. The sensitivity gradually decreases as the temperature decreases, and the sensitivity slightly increases as the temperature increases. Therefore, the temperature dependency of nitric oxide sensitivity of FECS41-250 can be compensated by a NTC thermistor.

* Test conditions: Gas flow rate 0.6 L/min (dry gas)

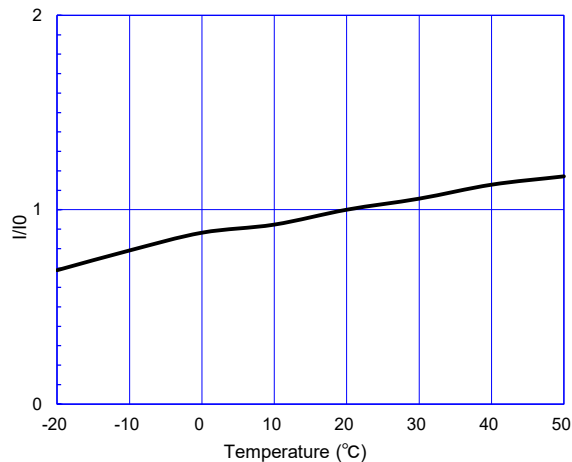

Fig. 7 - Temperature dependency (I₀=sensor output current at 20°C)

4. Cautions

4-1 Conditions for use and storage

1) Rated temperature and humidity conditions

Using or storing the sensor in an environment outside the rated temperature and humidity range may cause physical damage and/or affect the sensor characteristics.

2) Storage conditions

- Store the sensor in clean ambient air of normal temperature and humidity; recommended temperature from 0°C to 20°C. When storing for a long time, store the sensor in a sealed container such as a sealed bag.

- When the sensor is removed from a PC board and is stored, the reference electrode pin and the working electrode pin should be short-circuited using a shorting clip.

3) Condensation

If water condenses inside the sensor housing, sensor characteristics may drift.

4) Oxygen concentration

The sensor cannot operate continuously in a zero oxygen content atmosphere.

5) High concentration of gases

Sensor performance may be affected if exposed to a high concentration of gases for a long period of time during an operating or storage period.

6) Organic vapors

If the sensor is exposed to organic vapors generated from alcohol, acetone, volatile oil etc., organic vapors will adsorb onto the sensing element surface and sensor performance may be affected.

7) Dust and oil mist

Sensor performance may be affected if exposed where excessive dust, fine particles or oil mist is present.

4-2 Handling

1) Applied voltage

Do not apply voltage to the sensor. If voltage is applied to the sensor pins, sensor characteristics may

be affected. Do not use the sensor once the voltage required for electrolysis of water or higher is applied.

2) Shorting clip

Sensors are shipped short-circuited. Remove the shorting clip connected between the reference pin and the working pin just before use.

3) Mechanical shock and vibration

Avoid mechanical shock. Change in sensor characteristics or electrolyte leakage may occur if the sensor is subjected to a strong shock or vibration. Do not use the sensor if subjected to a drop or other mechanical shock.

4) Soaking

Avoid contact with water. Sensor characteristics may be affected due to soaking or splashing the sensor with water.

5) Disassembly or deformation

Under no circumstances should the sensor be disassembled, nor should the sensor structure be deformed. Electrolyte leakage may occur as a result. Such action would void the sensor warranty.

6) Gas inlet

Do not block the gas inlet of sensor. The sensor would not work properly with a clogged inlet.

7) Non-woven filter

Do not remove the non-woven filter on the sensor top nor make it dirty. Do not insert foreign objects through the non-woven filter. This may damage the sensor, leading to leakage of electrolyte.

4-3 Mounting process

1) Soldering

Always use appropriate pin sockets to install the sensor onto a PC board. Do not solder sensor pins. Soldering the sensor pin may lead to leakage of electrolyte.

2) Electrical connector grease

Do not use electrical connector grease when installing the sensor into a circuit. This may lead to deterioration of the sensor housing material.

3) Resin coating

When a resin coating is applied on a printed circuit board for improving its resistance to moisture, the chemical solvent contained in the coating material may affect sensor characteristics. Sample testing should be conducted to see if this process would adversely affect sensor characteristics.

4) Electro static discharge

Exercise necessary precaution against ESD during mounting of the sensors on finished instruments.

5) Resonance

Excessive vibration may cause damage of the sensor structure or break of the sensor components at the resonance frequency. Usage of compressed air drivers or ultrasonic welders on assembly lines may cause such vibration to the sensor. Before using such equipment, preliminary tests should be conducted to verify that there will be no influence on sensor characteristics.

4-4 Application design

1) Foreign conductive objects

If foreign conductive objects get into the sensor, short-circuit may occur inside the sensor. When such conditions are expected to be encountered, installation of an external air filter is recommended.

2) Calibration and adjustment

Periodic calibration and adjustment are required to maintain proper sensor performances. Perform calibration and adjustment at an appropriate interval according to the detection accuracy required; typically once a year or every six months.

3) Fitness for purpose

Before usage of the sensor, customers should verify and ensure that the sensor will work properly under the conditions where they intend to use it, and that the sensor is fit for the purpose for which customers wish to use it.

5. Warranty

FECS-series gas sensors are warranted for 12 months after the date of purchase from Figaro.

6. Frequently Asked Questions

Q1: Why is the reference electrode and working electrode short-circuited when the sensor is stored?

A: If the reference electrode and working electrode pins are not short-circuited, in the process of the electrochemical reaction, polarization due to the reaction layer near the electrode, or internal resistance received when hydrogen ions move in the electrolyte, will cause a voltage drop.

The reference electrode detects the potential of the working electrode, and keeps the potential of the working electrode constant regardless of this voltage drop, and controls so that a current proportional to the gas concentration always flows between the working electrode and the counter electrode.

Q2: Why should the sensor not be soldered to the pins?

A: If the electrode pin is directly soldered, the sensor characteristics may be affected due to damage to the reservoir or sealing material. In addition, it may cause electrolyte leakage, which may affect inspection equipment. Please do not solder the electrode pins directly. Please make sure to connect the sensor to the socket pins recommended by Figaro.

The following are the recommended socket pins of FECS-series gas sensors:

Recommended specifications:

- Basically fitting male pin diameter is $\phi 1.5$ mm
- Male pin insertion depth is 4.3 mm or more

Socket pins (example):

- S.E.R. Corporation: SS 6000-00
- Mac Eight Co., Ltd: PD-152

Q3: What is the electrolyte?

A: For the electrolyte, acidic solutions, alkaline solutions, and aqueous solutions are used.

FECS41-250 is sealed with a structure that does not leak electrolyte easily. However, if the sensor is incorrectly handled, the measuring equipment may be affected by corrosion due to electrolyte leakage. Please use the sensor according to *Item 4-Cautions*.

Q4: How should the sensor be disposed?

A: Spent FECS41-250 sensors should be disposed of in accordance with applicable regional, national, and local laws and regulations.

Figaro reserves the right to make changes without notice to any products herein to improve reliability, functioning or design. Information contained in this document is believed to be reliable. However, Figaro does not assume any liability arising out of the application or use of any product or circuit described herein; neither does it convey any license under its patent rights, nor the rights of others.

FECS-series gas sensors are not authorized for use as critical components in life support applications wherein a failure or malfunction of the products may result in injury or threat to life.

FIGARO ENGINEERING INC.
1-5-11 Senba-nishi
Mino, Osaka 562-8505 JAPAN
Phone: (81)-727-28-2045
email: figaro@figaro.co.jp
www.figaro.co.jp