



**SMALL-SIZE EXPLOSIVE GAS
MEASURING SENSOR
MIPEX-02**



Features

- ☑ Ultra-low power consumption – less than 3.5 mW.
- ☑ Fully digital.
- ☑ Durable stainless-steel housing.
- ☑ Fast response time (T90 < 6 s).
- ☑ Smart sensor with embedded microcontroller returns linearized, temperature-compensated output data (-40...+60 °C).
- ☑ Industry standard size (ø20.2×16.6 mm).
- ☑ Provides intrinsically safe explosion protection level “ia”.
- ☑ Does not require metal-ceramic filters (sinters).

Description

MIPEX-02 is intended for automatic continuous measurement of hydrocarbons or carbon dioxide concentration in atmosphere of hazardous areas.

Sensor operating principle is based on NDIR technology, i.e. on selective absorption of LED produced infrared radiation by gas molecules.

Differential dual wavelength method allows eliminating of water vapor, optical elements contamination and other non-selective hindrances influence.

Communication interface – UART.

Technical specification

General specification		
Gas sampling method:	Diffusion	
Operating principle:	Non-Dispersive Infra-Red (NDIR)	
Target gas	CH ₄	
	CH ₄ /CH ₄ +C ₂ H ₆	
	C ₃ H ₈	
	CO ₂	
Operating, storage and transportation conditions:	Relative humidity, %	up to 98
	Atmospheric pressure, kPa	80...120
	Temperature, °C	-55...+60
Warm-up time, sec	120	
Overall dimensions, mm	∅20.2×16.6 (w/o pins)	
	∅22×16.6 (w/o pins)	
Weight, g	16.6 (housing type "1")	
	15.5 (housing type "2")	
	5.5 (housing type "3")	
Housing material	Stainless steel	
	Polycarbonate Lexan™	

Measurement specification	
Measurement range, % vol.	0...1.5 (CO ₂ or C ₃ H ₈ sensors)
	0...2.5 (CH ₄ or C ₃ H ₈ sensors)
	0...5 (CH ₄ sensors)
	0...100 (CH ₄ sensors)
Readings variability (+20...+25 °C)*	± 0.1% vol. or ± 5% of readings (whichever is greater) for CH ₄
	± 0.05% vol. or ± 5% of readings (whichever is greater) for C ₃ H ₈ / CO ₂
Response time (T₉₀), sec	≤ 5 (C _m H _n , housing "2")
	≤ 15 (C _m H _n , housing "1" and "3")
	≤ 10 (CO ₂ , housing "2")
	≤ 30 (CO ₂ , housing "1" and "3")
Response time (T₉₀) with dust filter applied, sec	≤ 10 (C _m H _n , housing "2")
	≤ 30 (C _m H _n , housing "1" and "3")
	≤ 20 (CO ₂ , housing "2")
	≤ 60 (CO ₂ , housing "1" and "3")

Electrical specification	
Operating supply voltage, VDC (min...max)	+3.0...+5.0
Communication interface	UART
Average current, mA	≤ 1.1

* Variability in whole operating temperature range for any sensor modification presented below.

Calibration gas	Readings variability within a temperature range	Additional variability due to pressure	Additional variability due to humidity
CH ₄	± 0.1% vol. or ± 5% of readings (whichever is greater) within the range of +20...+25 °C;	± 0.2% vol. or ± 30% of readings (whichever is greater) at 100 kPa (test: 80 kPa, 100 kPa, 120 kPa)	± 0.2% vol. or ± 15% of readings (whichever is greater) at 40 °C (test: 20% RH, 50% RH, 90% RH)
	± 0.2% vol. or ± 10% of readings (whichever is greater) within the range of -10...+20 °C and +25...+40 °C;		
	± 0.4% vol. or ± 20% of readings (whichever is greater) within the range of -40...-10 °C and +40...+60 °C.		
C ₃ H ₈ , CO ₂	± 0.05% vol. or ± 5% of readings (whichever is greater) within the range of +20...+25 °C;	± 0.1% vol. or ± 30% of readings (whichever is greater) at 100 kPa (test: 80 kPa, 100 kPa, 120 kPa)	± 0.1% vol. or ± 15% of readings (whichever is greater) at 40 °C (test: 20% RH, 50% RH, 90% RH)
	± 0.1% vol. or ± 10% of readings (whichever is greater) within the range of -10...+20 °C and +25...+40 °C;		
	± 0.2% vol. or ± 20% of readings (whichever is greater) within the range of -40...-10 °C and +40...+60 °C.		

Ordering info

Part number structure:

MIPEX-02-B-C-D.1 A (RX)

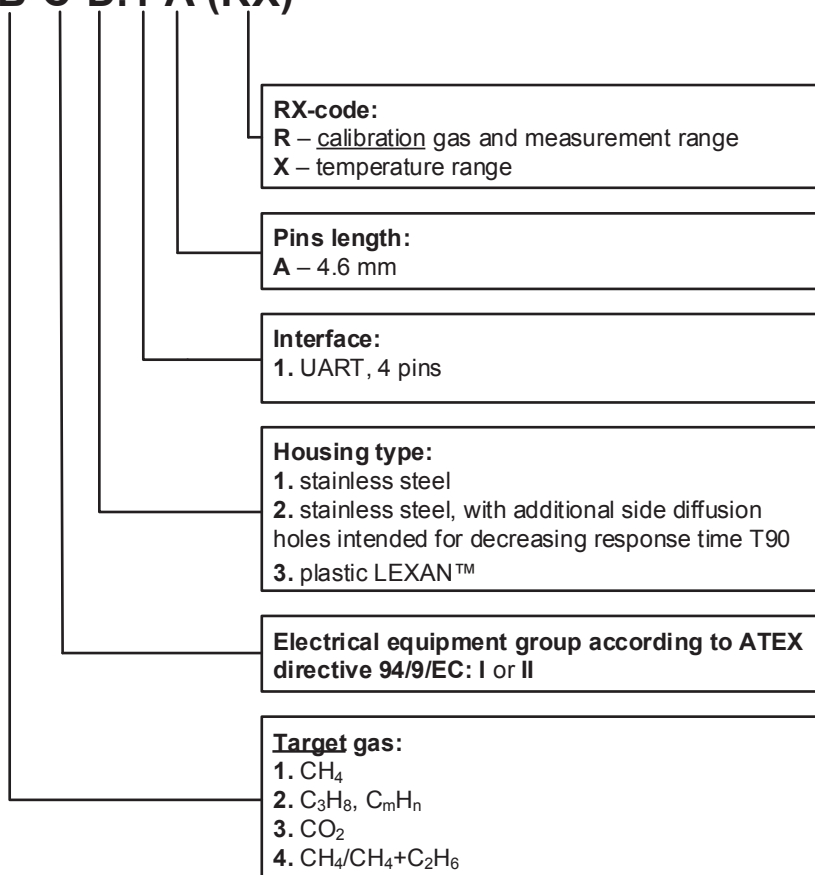

Term **target gas** refers to LED and photodiode spectral range, which is adjusted for best detection of a certain gas, while term **calibration gas** refers to gas mixture used for sensor calibration.

Part number	Target gas	Calibration gas	Meas. range, % vol.	Temp. range, °C	RX-code		
MIPEX-02-1-I-D.1 A (00)	CH ₄	CH ₄	0...2.5	-10...+40	00		
MIPEX-02-1-I-D.1 A (10)			0...5		10		
MIPEX-02-1-I-D.1 A (20)			0...100		20		
MIPEX-02-1-II-D.1 A (01)			0...2.5	-40...+60	01		
MIPEX-02-1-II-D.1 A (11)			0...5		11		
MIPEX-02-1-II-D.1 A (21)			0...100		21		
MIPEX-02-1-II-D.1 A (02)			0...2.5	-20...+50	02		
MIPEX-02-1-II-D.1 A (12)			0...5		12		
MIPEX-02-1-II-D.1 A (22)			0...100		22		
MIPEX-02-1-II-D.1 A (61)			C ₃ H ₈	C ₃ H ₈	0...1.5	-40...+60	61
MIPEX-02-1-II-D.1 A (71)					0...2.5		71
MIPEX-02-1-II-D.1 A (62)					0...1.5	-20...+50	62
MIPEX-02-1-II-D.1 A (72)					0...2.5		72
MIPEX-02-2-II-D.1 A (61)			C ₃ H ₈	C ₃ H ₈	0...1.5	-40...+60	61
MIPEX-02-2-II-D.1 A (71)	0...2.5	71					
MIPEX-02-2-II-D.1 A (62)	0...1.5	-20...+50			62		
MIPEX-02-2-II-D.1 A (72)	0...2.5				72		
MIPEX-02-3-I-D.1 A (30)	CO ₂	CO ₂	0...1.5	-10...+40	30		
MIPEX-02-3-II-D.1 A (32)				-20...+50	32		
MIPEX-02-4-I-D.1 A (00)	CH ₄ /CH ₄ +C ₂ H ₆	CH ₄	0...2.5	-10...+40	00		
MIPEX-02-4-I-D.1 A (10)			0...5		10		
MIPEX-02-4-I-D.1 A (20)			0...100		20		
MIPEX-02-4-II-D.1 A (01)			0...2.5	-40...+60	01		
MIPEX-02-4-II-D.1 A (11)			0...5		11		
MIPEX-02-4-II-D.1 A (21)			0...100		21		
MIPEX-02-4-II-D.1 A (02)			0...2.5	-20...+50	02		
MIPEX-02-4-II-D.1 A (12)			0...5		12		
MIPEX-02-4-II-D.1 A (22)			0...100		22		

Typical sensor cross-sensitivity to hydrocarbons and accuracy

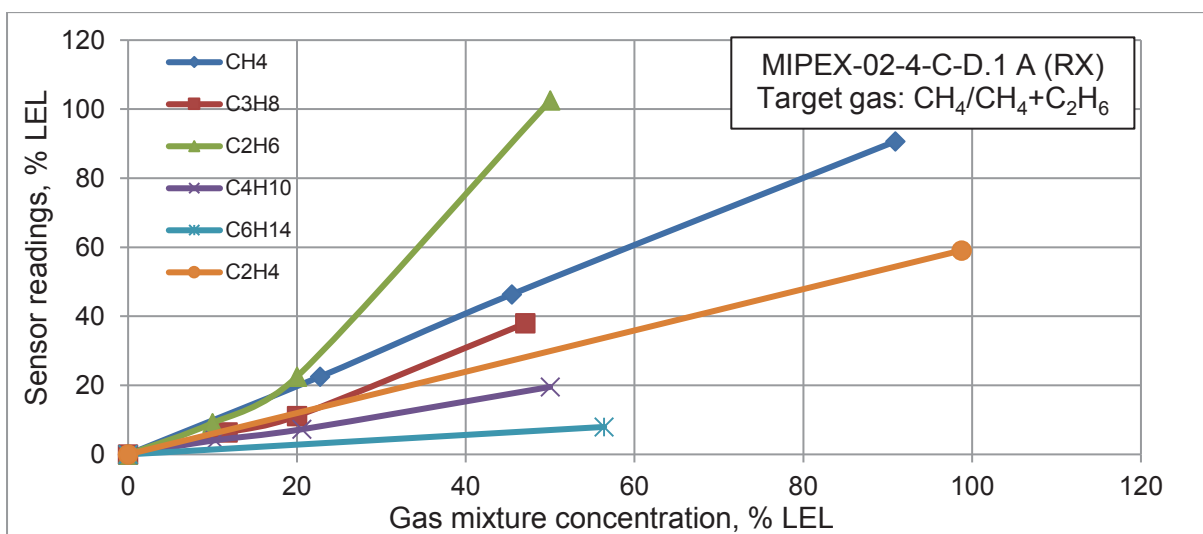
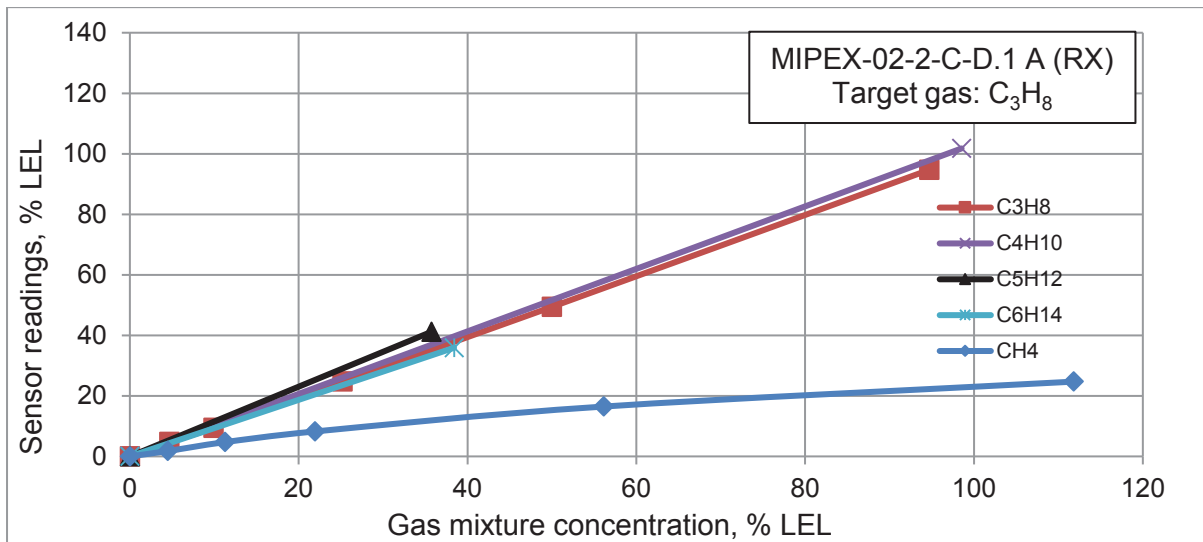
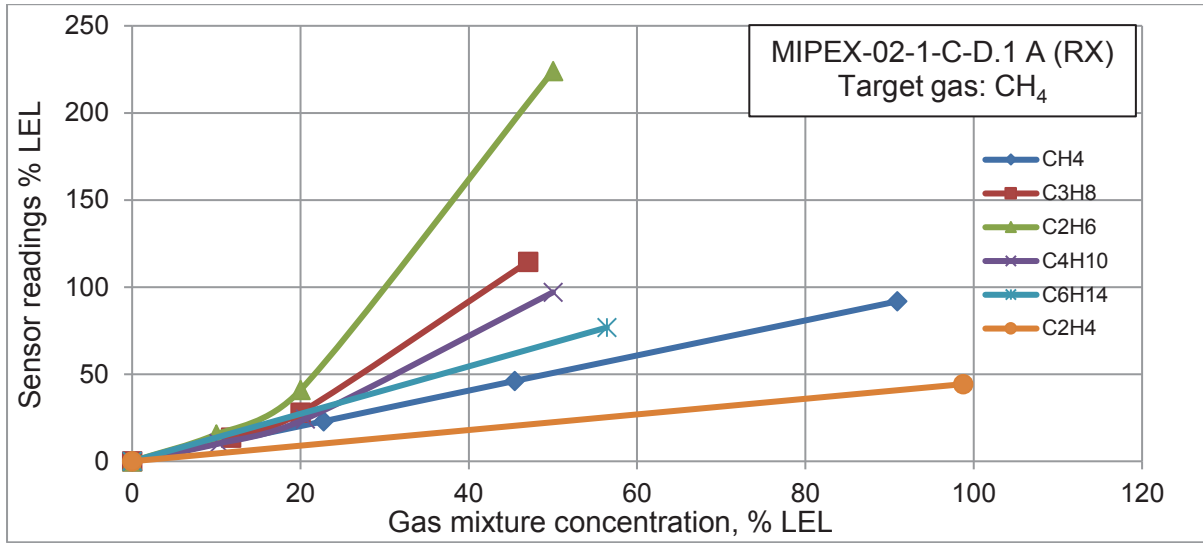

Current consumption

Average current consumption is not more than 1.1 mA at request rate less than 1 Hz.

Intrinsic safety

Sensor complies with the international standards listed below.

IEC/EN 60079-0, IEC/EN 60079-11:

- Explosion protection level – “ia”;
- Hazardous area class (Electrical equipment group) – “I” and “IIC”;
- Intrinsic safety parameters: $P_i = 0.25\text{ W}$, $U_i = 5.0\text{ V}$, $I_i = 450\text{ mA}$, $C_i = 38.8\text{ }\mu\text{F}$, $L_i = 0\text{ mH}$.

UL913, CAN/CSA-C22.2 No. 157-92:

- Class I, Division 1, Group A, B, C, D.
- Intrinsic safety parameters: $P_{\max} = 0.25\text{ W}$, $U_{\max} = 5.0\text{ V}$, $I_{\max} = 450\text{ mA}$, $C_i = 38.8\text{ }\mu\text{F}$, $L_i = 0\text{ mH}$.

Handling precautions

Maximum allowable pressure for housing types “1” and “2”: on the central part of sensor reflecting cover or on sensor side surface – 2 MPa, on sensor upper edge – 100 MPa.

Maximum allowable pressure for housing type “3”: on the central part of sensor reflecting cover or to sensor side surface – 20 kPa, on sensor upper edge – 2 MPa.

Sensor is not intended to measure hydrocarbons contained in fluids.

Sensor housing type “3” may accumulate an electrostatic charge. Thus, there is risk of electrostatic discharge. Clean only using a damp cloth.

Gas holes of sensor should be protected against ingress of dust and sprayed materials.

Sensor must be mounted using sockets only, as soldering the pins may damage sensor.

There is no risk of pollution and negative impact on human health. Sensor does not contain any harmful substances that may be released during its normal operation.

Sensor pinout (bottom side)

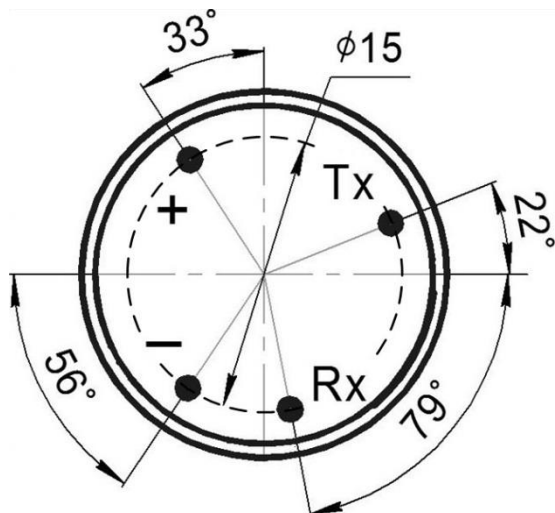

Pin	Purpose
Tx	UART, TxD output
Rx	UART, RxD input
+	V _{DD}
-	GND

Outline

All dimensions are in millimeters.

Type "1"

Metal housing
MIM SS 316

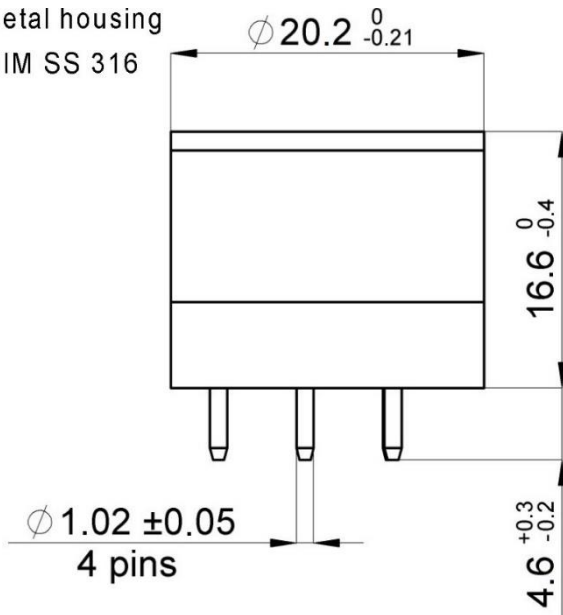

Type "2"

Metal housing
MIM SS 316

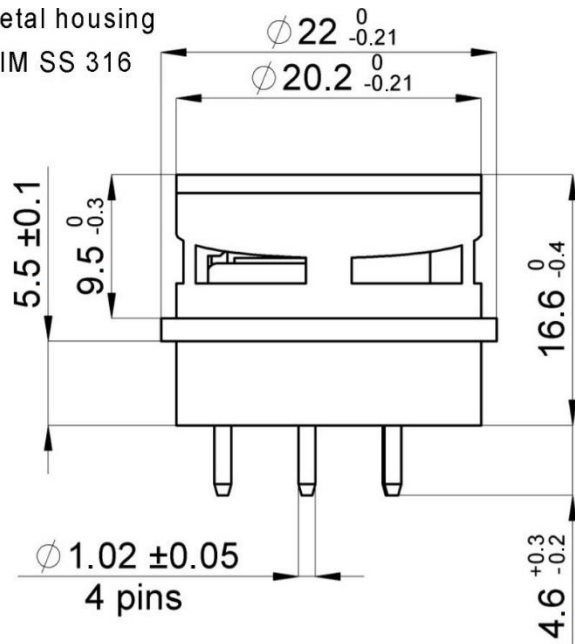

Type "3"

Plastic housing
PLASTIC LEXAN™ 943A

