

**Technical Information for
Figaro Lead-Free Oxygen Sensor TGS4260**

TGS4260 is a potentiostatic electrolysis-type oxygen sensor which has a wide measuring range and operating temperature range. It is easy to incorporate this sensor in size oriented applications such as portable oxygen detectors and multi-gas detectors.



	<u>Page</u>
Basic Information and Specifications	
Features.....	2
Applications.....	2
Structure and Dimensions.....	2
Operating Conditions and Specifications.....	2
Recommended Measuring Circuit.....	3
Operation Principle.....	3
Basic Sensitivity Characteristics	
Sensitivity Characteristics.....	4
Response Time.....	4
Repeatability.....	4
Cross Sensitivity.....	5
Temperature Dependency.....	5
Reliability	
Long Term Stability (Ambient conditions).....	6
Drop impact test.....	6
Cautions.....	7

IMPORTANT NOTE: OPERATING CONDITIONS IN WHICH FIGARO SENSORS ARE USED WILL VARY WITH EACH CUSTOMER'S SPECIFIC APPLICATIONS. FIGARO STRONGLY RECOMMENDS CONSULTING OUR TECHNICAL STAFF BEFORE DEPLOYING FIGARO SENSORS IN YOUR APPLICATION AND, IN PARTICULAR, WHEN CUSTOMER'S TARGET GASES ARE NOT LISTED HEREIN. FIGARO CANNOT ASSUME ANY RESPONSIBILITY FOR ANY USE OF ITS SENSORS IN A PRODUCT OR APPLICATION FOR WHICH SENSOR HAS NOT BEEN SPECIFICALLY TESTED BY FIGARO.

1. Basic Information and Specifications

1-1 Features

- * Lead-free
- * In 20mm industrial standard package
- * Linear output
- * Quick response to Oxygen
- * High repeatability/selectivity to O₂
- * Long life
- * High impact resistance

1-2 Applications

- * Oxygen monitors
- * Stationary O₂ detectors
- * Portable O₂ detectors
- * Multi-gas detectors

1-3 Structure and Dimensions

Figure 1 shows the structure and dimensions of the sensor.

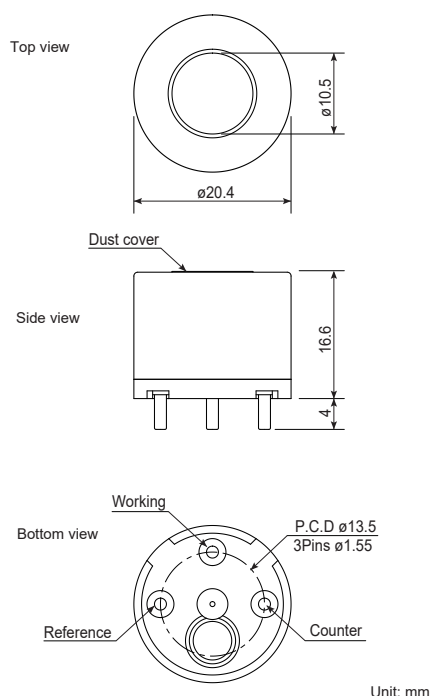

Fig. 1 - Sensor dimensions

1-4 Operating Conditions and Specifications

The specifications shown in the table 1 are based on the standard test conditions, using Figaro's recommended measuring circuit.

- *1: When tested under constant operating conditions
- *2: When tested within the range from -20°C to 60°C
- *3: Under standard test conditions of 20°C, 50%RH and 1013 hPa
- *4: A range -40°C ~ 60°C is valid only for a limited time use.
(-20°C ~ 50°C for continuous operation)
- *5: A range 5 ~ 95 %RH is valid only for a limited time use.
(15 ~ 90%RH for continuous operation with no condensation)
- *6: No sudden changes of ambient temperature or humidity

All sensor characteristics shown in this document represent typical characteristics. The only characteristics warranted are those shown in the Specification table above.

Model Number	TGS4260
Detection Gas	Oxygen
Detection Range	0 ~ 25 vol.%
Maximum Overload	30 vol.%
Output Signal	-80 ~ -130 μA in Air
Repeatability	± 2% (*1)
Resolution	0.1 vol.%
Response Time (t ₉₀)	< 10 sec (*2)
Long Term Output Drift	< 5% over operating life (*3)
Expected Life Time	> 5 years (*3)
Operating Temperature	-40°C ~ 60°C (*4)
Operating Humidity	5% RH ~ 95% RH (*5)
Operating Pressure Range	100kPa ± 20kPa
Recommended Load Resistor	20 Ω
Bias Voltage	-600mV ± 10mV
Position Sensitivity	None
Recommended Storage Temp.	0°C ~ 20°C
Weight	6.0g (approx.)
Warm-Up Time	2hour. or more (*6)

Table 1 - Specifications of TGS4260 (tentative)

1-5 Recommended Measuring Circuit

Figure 2 shows the recommended measuring circuit for use with TGS4260.

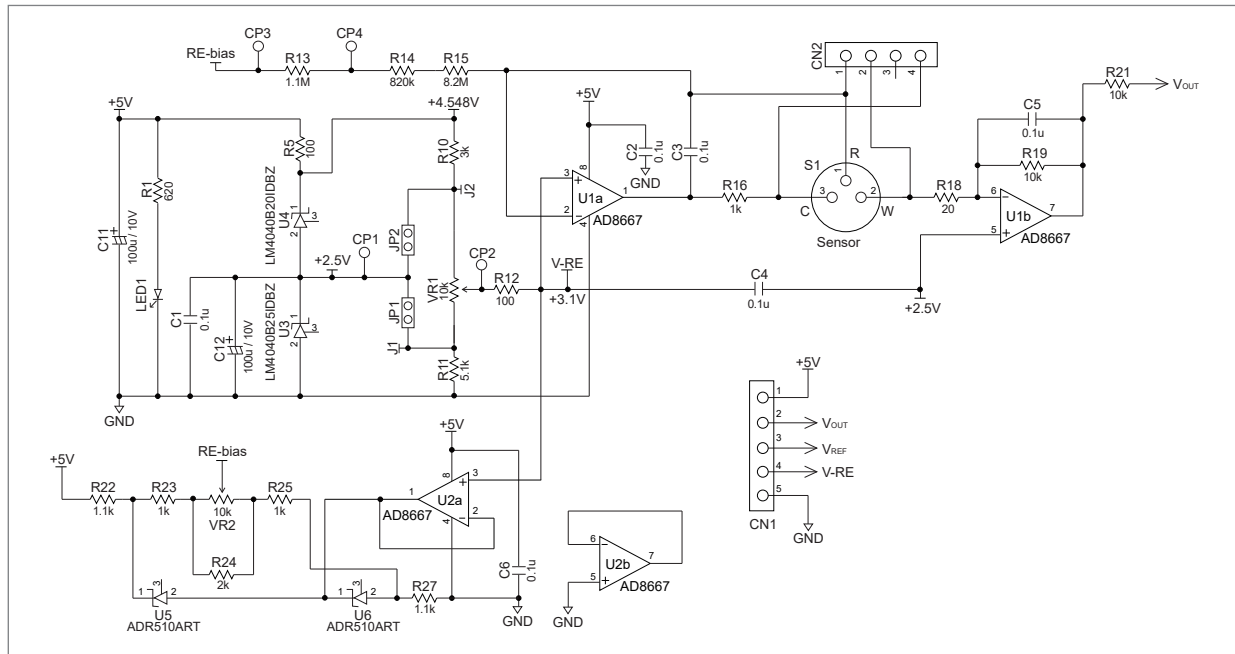

Fig. 2 - Recommended measuring circuit

1-6 Operation Principle

TGS4260 is a potentiostatic electrolysis-type oxygen sensor. Figure 3 shows the structure of TGS4260 oxygen sensor. The working electrode (WE), the counter electrode (CE), and the reference electrode (RE) respectively comprise a gas permeable membrane and a noble metal catalyst, all of which are in contact with the liquid electrolyte and contained in a resin housing. The electrolytic current generated between WE and CE is measured while an external power supply (potentiostatic circuit) controls the potential of the WE with respect to the RE potential. When TGS4260 sensor is placed where oxygen is present, by maintaining the potential of the WE at a predetermined negative value with respect to the RE potential, reduction of oxygen occurs on the WE, and oxidation of water occurs on the CE at the same time. During these electrochemical reactions, ionic conduction occurs in the electrolyte and electronic conduction occurs in the external circuit. Output voltage proportional to oxygen concentrations can be measured by converting the generated electrolytic current which is proportional to oxygen concentration.

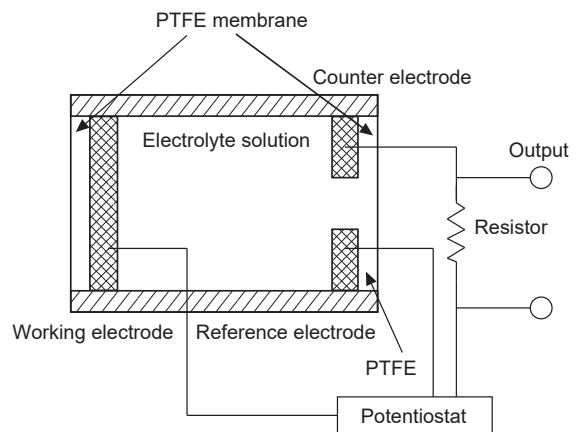
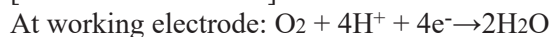

Fig. 3 - Schematic diagram of operating principle

[The reaction formula]



2. Basic Sensor Characteristics

2-1 Sensor Characteristics

Figure 4 shows the typical sensor response and linearity of TGS4260 to O₂ measured under standard test conditions using the recommended measuring circuit. TGS4260 has excellent linearity to O₂ in the range of 0~25 vol.% O₂.

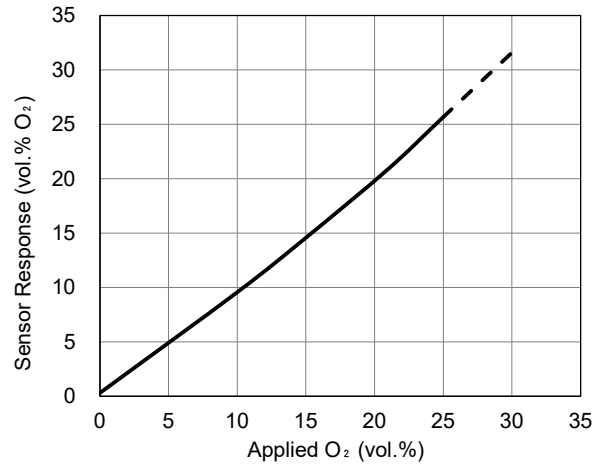

Fig. 4 - Typical sensor characteristics of TGS4260

2-2 Response Time

Figure 5 demonstrates the typical response pattern of the sensor output measured under standard test conditions using recommended measuring circuit when the sensor is placed into 100 vol.% N₂ (i.e. 0 vol.% O₂) and then returned to normal air of 20.9 vol.% O₂. Typical response time to 90% of the saturated response level (t₉₀) is approximately 10 seconds.

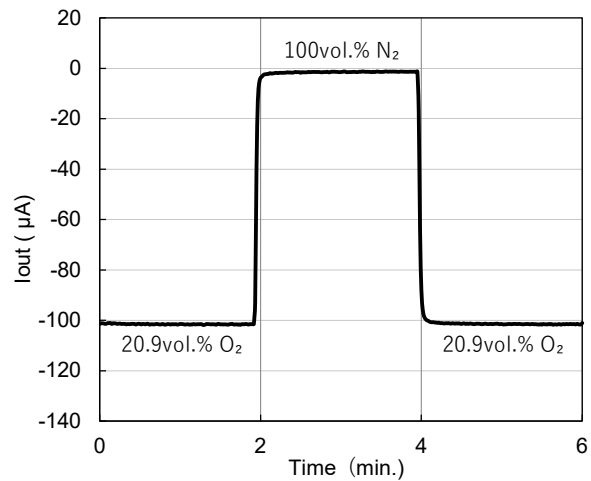

Fig. 5 – Typical Response pattern of TGS4260

2-3 Repeatability

Figure 6 demonstrates excellent repeatability of the sensor output measured using the recommended measuring circuit under standard test conditions when the sensor is repeatedly placed into 100 vol.% N₂ for 2 minutes and then returned to normal air of 20.9 vol.% O₂ for 2 minutes.

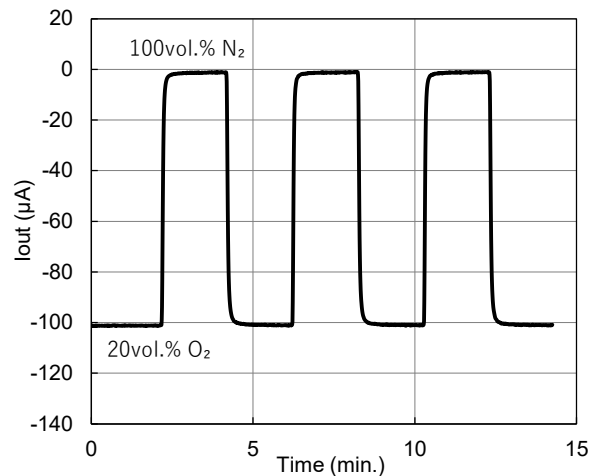

Fig. 6 - Repeatability of TGS4260

2-4 Cross Sensitivity

Figure 7 shows the typical response of TGS4260 to interference gases under standard test conditions. As shown in this table, the sensor has little sensitivity to almost all gases other than O₂ and has excellent selectivity to O₂.

Gas	Concentration	Display readings in vol.% O ₂
Oxygen	20.9%	20.9%
Hydrogen	5,000ppm	20.1-20.2% O ₂
Carbon Monoxide	500ppm	20.8-20.9% O ₂
Carbon Dioxide	10,000ppm	20.8-20.9% O ₂
Hydrogen Sulfide	15ppm	20.8-20.9% O ₂
Sulphur Dioxide	30ppm	20.9%
Nitric Oxide	100ppm	20.7-20.8% O ₂
Nitrogen Dioxide	100ppm	20.9-21.0% O ₂
Ozone	1ppm	20.8-20.9% O ₂
Acetone	1,000ppm	20.8-20.9% O ₂
Ethanol	1,000ppm	20.8-20.9% O ₂

Fig. 7 - Cross sensitivity of TGS4260 (@20°C)

2-5 Temperature Dependency

Figure 8 represents typical temperature dependency of the sensor output and the response time measured under various temperature conditions in ambient air conditions of 20.9 vol.% O₂. The Y-axis on the left shows the ratio of output current in 20.9 vol.% O₂ at various temperatures to the output current in 20.9 vol.% O₂ at 20°C. The Y-axis on the right shows T₉₀ response time at various temperatures. The output current gradually decreases as ambient temperature decreases, and slightly increases as ambient temperature increases. The temperature dependency of TGS4260 can be compensated by utilizing a NTC thermistor. The response is very fast and has little temperature dependence in the wide range of temperature.

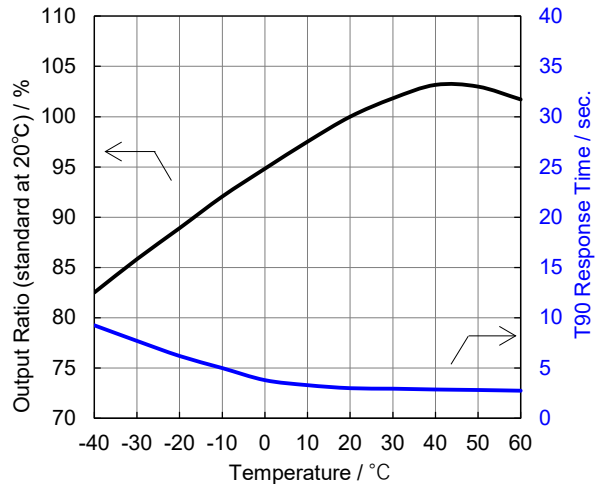

Fig. 8 - Temperature dependency

3. Reliability

3-1 Long Term Stability

Figure 9 displays long term stability data showing the sensor output signals in 20.9 vol.% O₂ measured using the recommended measuring circuit with the load resistor being 1 kohm.

The Y-axis shows pseudo display readings in vol.% O₂ that are calculated by assuming the initial output current (I_o) in 20.9 vol.% oxygen measured on the first day of the test as 20.9 vol.% O₂. This chart demonstrates very stable characteristics for more than 2 years.

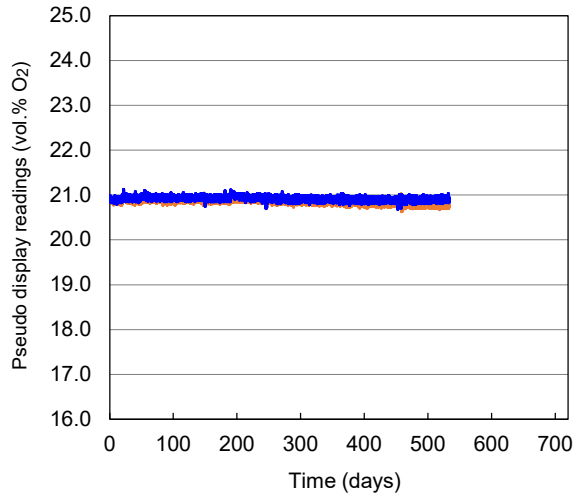

Fig. 9 - Long term stability of calculated display readings of TGS4260

3-2 Drop impact test

Resistance against mechanical shock on the sensor was verified by the drop test. The sensor was covered with a resin housing for protection and mounted inside a portable oxygen detector. The oxygen detector was permitted to drop from a height of 2 m onto a concrete plate placed on a floor 30 times. Fig. 10 shows the response pattern of the display readings measured under the standard test conditions when the detector was placed into 100 vol. % N₂ (i.e., 0 vol. % O₂) and then returned to normal air of 20.9 vol. % O₂ before and after the drop impact test. This demonstrates that there is no significant influence from this drop impact test on the sensor performance.

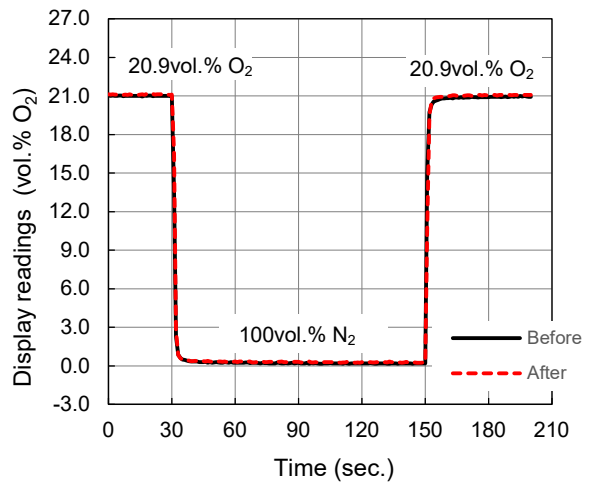

Fig. 10 - Durability to drop impact

4 Cautions

4-1 Safety Precautions

- Carefully read product information and other technical information provided by Figaro before using our products, and confirm specifications and operating conditions.
- When designing an application circuit, please make sure that an accidental short circuit or open circuit of other electronic components would not cause the sensor to be subjected to excessive voltage, current, or temperatures exceeding the rated values.
- When designing application products, please make sure that a gas sensor malfunction would not
 - 1) cause adverse effects on other components,
 - 2) directly or indirectly impair the safety of application products that use gas sensors (e.g., emit smoke, cause fire, or other unstable states of application products).
- Consider adding safety measures for fail-safe where necessary, such as a protection circuit.

4-2 Conditions for use and storage

1) Rated temperature and humidity conditions

Using or storing the sensor in an environment outside the rated temperature and humidity range may cause physical damage and/or affect the sensor characteristics.

2) Storage conditions

Store the sensor in clean ambient air of normal temperature and humidity; recommended temperature from 0°C to 20°C. When storing for a long time, store the sensor in a moisture-proof bag such as an aluminum coated bag.

3) Condensation

If water condenses inside the sensor housing, sensor characteristics may drift.

4) Oxygen concentration

Continuous sensor operation in a zero oxygen content atmosphere may affect the sensor characteristics and is not recommended. If the sensor is exposed to higher than the specified oxygen concentration, sensor characteristics may drift, and/or the linearity may be affected.

5) High concentration of gases

Sensor performance may be affected if exposed to a high concentration of gases for a long period of time during the operating or storage period.

6) Organic vapors

If the sensor is exposed to organic vapors generated from alcohol, acetone, volatile oil etc., organic vapors will adsorb onto the sensing element surface, and sensor performance may be affected.

7) Dusts and oil mist

Sensor performance may be affected if exposed where dust, fine particles, or oil mist is present.

4-3 Handling

1) Applied voltage

Do not apply voltage exceeding the rated voltage to the sensor. If voltage is applied to the sensor, the sensor may be damaged.

2) Shorting clip

Sensors are shipped open-circuited. Under no circumstances should the working pin, and the reference pin and the counter pin be short-circuited. If any sensor pins are short-circuited, sensor performance may be affected.

3) Mechanical shock and vibration

Avoid mechanical shock. Change in sensor characteristics or electrolyte leakage may occur if the sensor is subjected to a strong shock or vibration. Do not use the sensor if subjected to a drop or other mechanical shock.

4) No soaking

Avoid contact with water. Sensor characteristics may be affected due to soaking or splashing the sensor with water.

5) No disassembly or deformation

Under no circumstances should the sensor be disassembled, nor should the sensor structure be deformed. Electrolyte leakage may occur as a result. Such action would void the sensor warranty.

6) Gas inlet

Do not block the gas inlet of sensor. The sensor would not work properly with a clogged inlet.

7) Non-woven filter

Do not remove the non-woven filter on the sensor top, and do not make it dirty. Do not insert foreign objects through the non-woven filter. This may damage the sensor, leading to leakage of electrolyte.

4-4 *Mounting process*

1) Soldering

The sensor pins should not be soldered directly to a PC board. The internal structure may be damaged by the heat of soldering, causing electrolyte leakage. Pin sockets should be used for sensor connection. (e.g. Mac8: PD-152)

2) Electrical connector grease

Do not use electrical connector grease when installing the sensor into circuit. This may lead to deterioration of the sensor housing material.

3) Resin coating

When a resin coating is applied on a printed circuit board for improving its resistance to moisture, the chemical solvent contained in the coating material may affect sensor characteristics. Sample testing should be conducted to see if this process would adversely affect sensor characteristics.

4) Electro static discharge

Exercise necessary precaution against ESD during mounting of the sensors on finished instruments.

5) Resonance

Excessive vibration may cause damage of the sensor structure or breakage of the sensor components at the resonance frequency. Usage of compressed air drivers or ultrasonic welders on assembly lines may cause such vibration to the sensor. Before using such equipment, preliminary tests should be conducted to verify that there will be no influence on sensor characteristics.

4-5 *Application design*

1) Foreign conductive objects

If foreign conductive objects get into the sensor, short-circuit may occur inside the sensor. When such conditions are expected to be encountered, installation of an external air filter is recommended.

2) Calibration and adjustment

Periodic calibration and adjustment are required to maintain proper sensor performance. Perform calibration and adjustment at an appropriate interval according to the detection accuracy required.

3) Fitness for purpose

Before usage of the sensor, customers should verify and ensure that the sensor will work properly under the conditions where they intend to use it and that the sensor is fit for the purpose for which customers wish to use it.

Figaro Engineering Inc. (referred to as Figaro) reserves the right to make changes without notice to any products herein to improve reliability, functioning or design. Information contained in this document is believed to be reliable. However, Figaro does not assume any liability arising out of the application or use of any product or circuit described herein; neither does it convey any license under its patent rights, nor the rights of others.

Figaro's products are not authorized for use as critical components in life support applications wherein a failure or malfunction of the products may result in injury or threat to life.

FIGARO ENGINEERING INC.
1-5-11 Senba-nishi
Mino, Osaka 562-8505 JAPAN
Phone: (81)-727-28-2045
URL: www.figaro.co.jp/en/